

1800 VW flywheel
cross-section
(1600 similar)

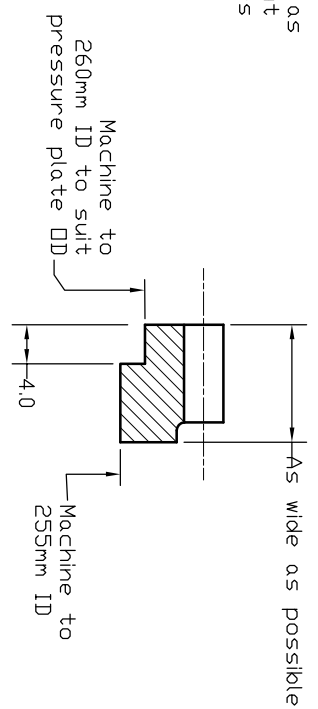
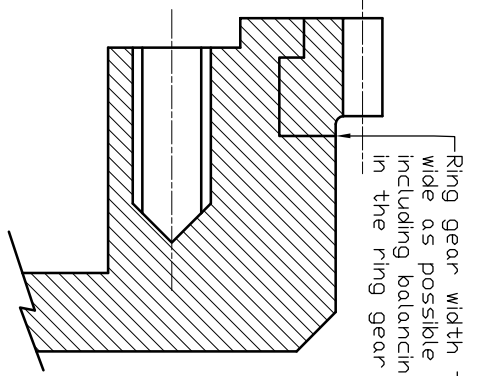
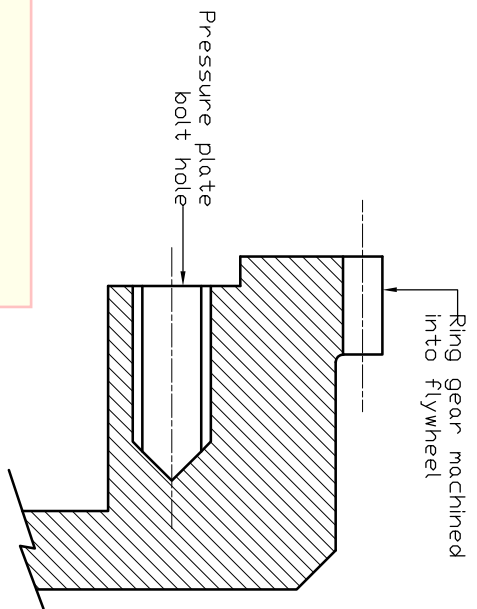

Ring gear piece to be used on V6 flywheel

Machine ring gear off of the VW flywheel as shown. Do not include balance holes in ring gear piece.

KLZE V6 flywheel cross-section

